

Echidna – the Engineering Challenges

Jurek Brzeski*, Peter Gillingham, David Correll, John Dawson, Anna Moore, Rolf Muller,
Scott Smedley, Greg Smith
Anglo-Australian Observatory, PO Box 296, Epping NSW 1710, Australia

ABSTRACT

The Anglo-Australian Observatory's (AAO's) FMOS-Echidna project is for the Fiber Multi-Object Spectroscopy system for the Subaru Telescope. It includes three parts: the 400-fiber positioning system, the focal plane imager (FPI) and the prime focus corrector. The Echidna positioner concept and the role of the AAO in the FMOS project have been described in previous SPIE proceedings. The many components for the system are now being manufactured, after prototype tests have demonstrated that the required performance will be achieved. In this paper, the techniques developed to overcome key mechanical and electronic engineering challenges for the positioner and the FPI are described. The major performance requirement is that all 400 science fiber cores and up to 14 guide fiber bundles are to be re-positioned to an accuracy of 10 μ m within 10 minutes. With the fast prime focus focal ratio, a close tolerance on the axial position of the fiber tips must also be held so efficiency does not suffer from de-focus. Positioning accuracy is controlled with the help of the FPI, which measures the positions of the fiber tips to an accuracy of a few μ m and allows iterative positioning. Maintaining fiber tips sufficiently co-planar requires accurate control in the assembly of the several components that contribute to such errors. Assembly jigs have been developed and proven adequate for this purpose. Attaining high reliability in an assembly with many small components of disparate materials bonded together, including piezo ceramics, carbon fiber reinforced plastic, hardened steel, and electrical circuit boards, has entailed careful selection and application of cements and tightly controlled soldering for electrical connections.

Keywords: Fiber positioner, piezoelectric actuators, Echidna, Subaru telescope

INTRODUCTION

The Fiber Multi-Object Spectrograph (FMOS) project is an Australia-Japan-UK collaboration to design and build a fiber positioner feeding two near infrared spectrographs from the Subaru telescope. The Anglo-Australian Observatory (AAO) FMOS project includes the fiber positioner, as shown in Figure 1 and Figure 2, which we call "Echidna" after an Australian mammal with movable spines on its back, a focal plane imager (FPI) shown in Figure 3 and a corrector lens. Echidna will position up to 400 fibers in a 30 arcmin diameter field of view at the prime focus of the telescope. Its advantage, compared with other multi-fiber positioners, is that so many fibers can be positioned in such a small physical area – 147 mm diameter in FMOS. The fibers are positioned using piezoelectric actuators that move spines carrying the optical fibers. The FPI measures the positions of the spine tips in the focal plane. The FPI can also image the sky to allow direct correlation of object and fiber positions. The prime focus corrector lens was designed to provide a flat, optically corrected focal plane for the Echidna fiber system, working from 900 to 1800 nm wavelength. This paper deals with Echidna and the FPI.

jkb@ao.gov.au phone: 612 9372 4820, fax: 9372 4881

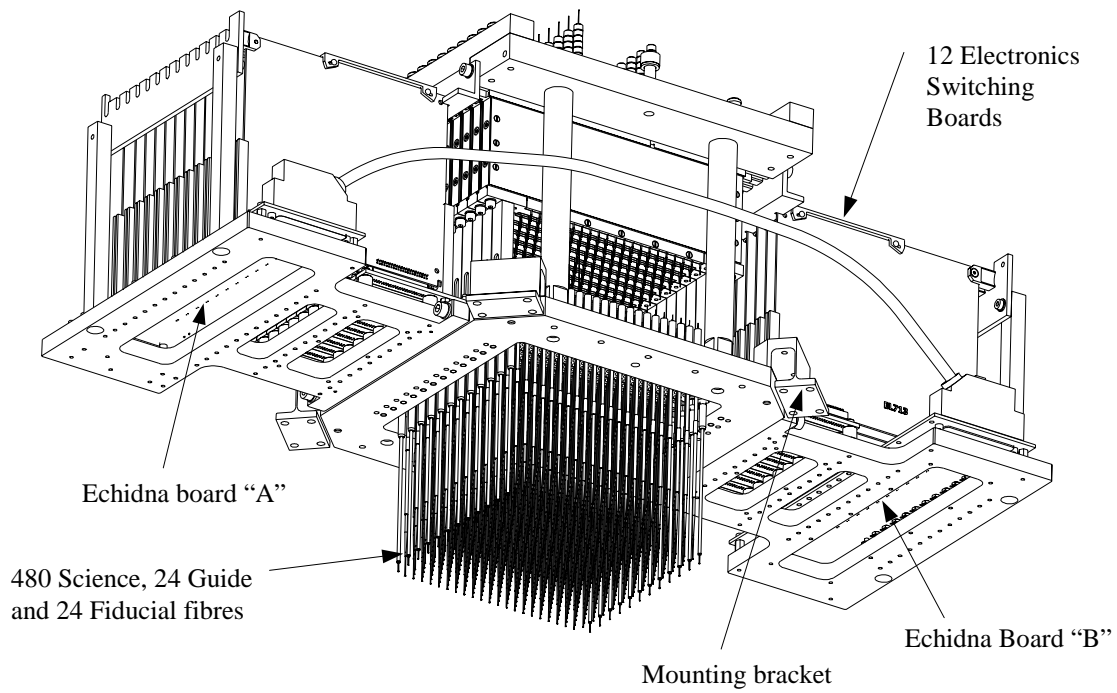

Figure 1. Echidna positioner assembly.

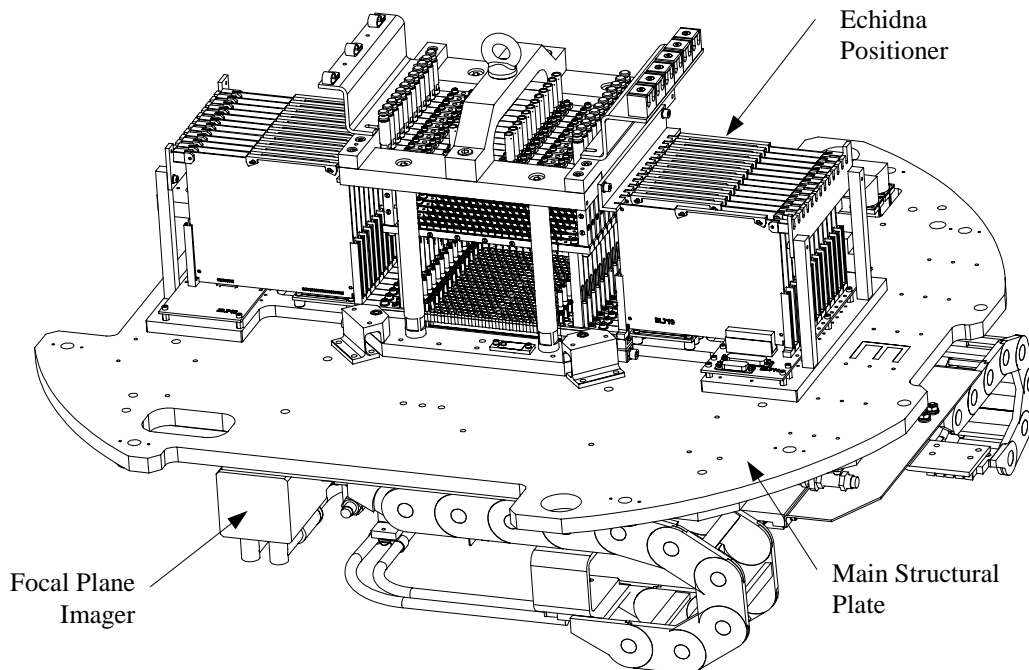

Figure 2. View of Echidna positioner mounted on FMOS main structural plate.

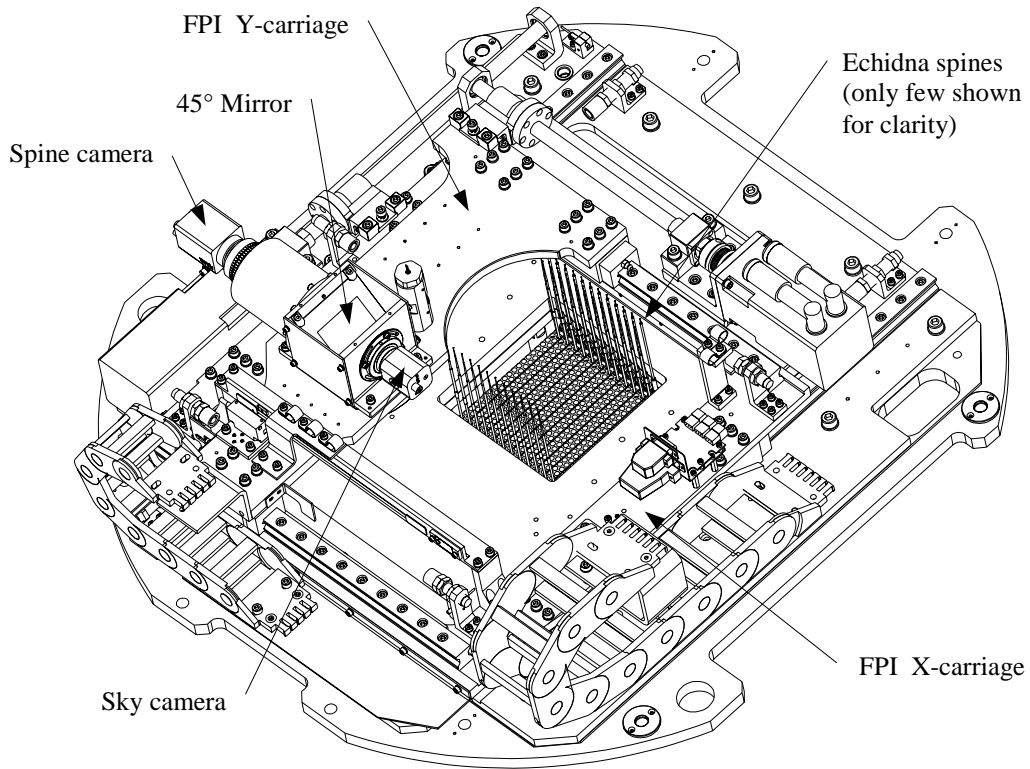

Figure 3. View of FPI on main structural plate (view from below)

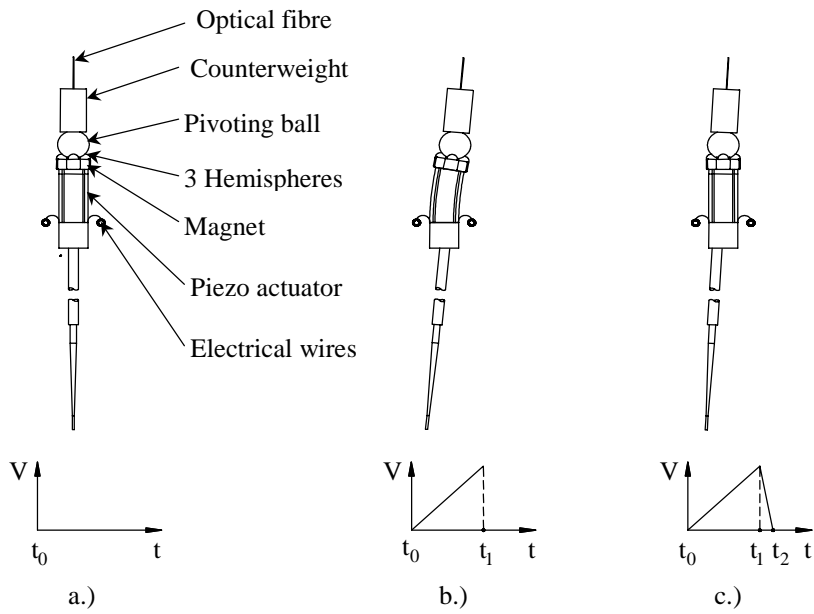

Figure 4. Illustration of one cycle of spine drive (not to scale). Tilt is greatly exaggerated.

Figure 4 illustrates the way in which the Echidna spines are driven in tip and tilt by applying a saw tooth alternating voltage to the actuator. A voltage, applied across the opposite electrodes of the tubular piezoelectric actuator, produces bending of the tube (see Figure 4b). With the attractive force due to the magnet, the friction between the ball and its mount is sufficient for the spine to follow the tilt of the piezo actuator during the relatively slow voltage rise. During the fast voltage drop the ball slips on the three point mount, leaving a net tilt of the spine (see Figure 4c). A similar saw tooth applied across the other pair of electrodes produces spine movement in the orthogonal direction, so the spine tip can be positioned at any point in a 14 mm diameter range. The net movement of the spine tip with each saw tooth cycle can be set between about 50 μm and about 8 μm with the range of voltage amplitude used in Echidna. The step size is not precisely predictable, so it is necessary to iterate to position a spine tip with the required 10 μm accuracy, with the FPI providing the feedback by measuring the new positions of the spines after each iteration. Details of performance of the spine drive are discussed in reference 1.

1. Echidna mechanical engineering

Manufacturing the fiber positioning system has presented an interesting range of engineering issues. The challenges included:

- designing and manufacturing of very high precision assemblies and their components with assembly tolerances in the 10s of microns;
- finding space for many hundreds of wires carrying high voltage signals;
- selection of appropriate adhesives for joining several types of materials;
- fibre optics management.

1.1. Echidna mechanical design challenges

1.1.1. Echidna space constraints

One of the major problems in the early stage of FMOS – Echidna design was finding space for a few hundred micro positioning actuators and allowing for ease of assembly and maintenance. A modular system was adopted in which the field of view is covered by 12 identical rectangular modules (see Figure 5), each positioning 40 science fibers and 2 guide fibers. (Some of the science and guide spines are out of the field of view). The modular arrangement allows maintenance by exchanging modules and minimizes the difficulties of construction. All science and guide fibers are located on the three point mounts described earlier and shown on Figure 4.

1.1.2. Piezo actuators construction

The piezo actuators are assembled from a ceramic piezo tube, a rare earth NdFeB magnet and 3 austenitic stainless steel hemispheres. While held in a jig, the piezo actuators are glued into the module base.

Challenges

Initially, the 3-point mount incorporated a standard ring magnet (Figure 6a). The hemisphere-to-magnet joints were weak. Partly because the hemispheres were overhanging the cylindrical magnet and partly because of insufficient strength of the 2-part epoxy used. The magnet to piezoelectric tube joint was also weak. Several magnets detached from their piezo tubes during module assembly as the force from magnetic attraction and repulsion often exceeded the strength of the bond during cure. The nature of the magnet material did not allow us to roughen the surface, since penetration of the plating could have resulted in corrosion and eventual deterioration of the magnet.

Excessive wear between the spine pivoting ball and the 3-point contact surfaces was occurring on the hemispheres.

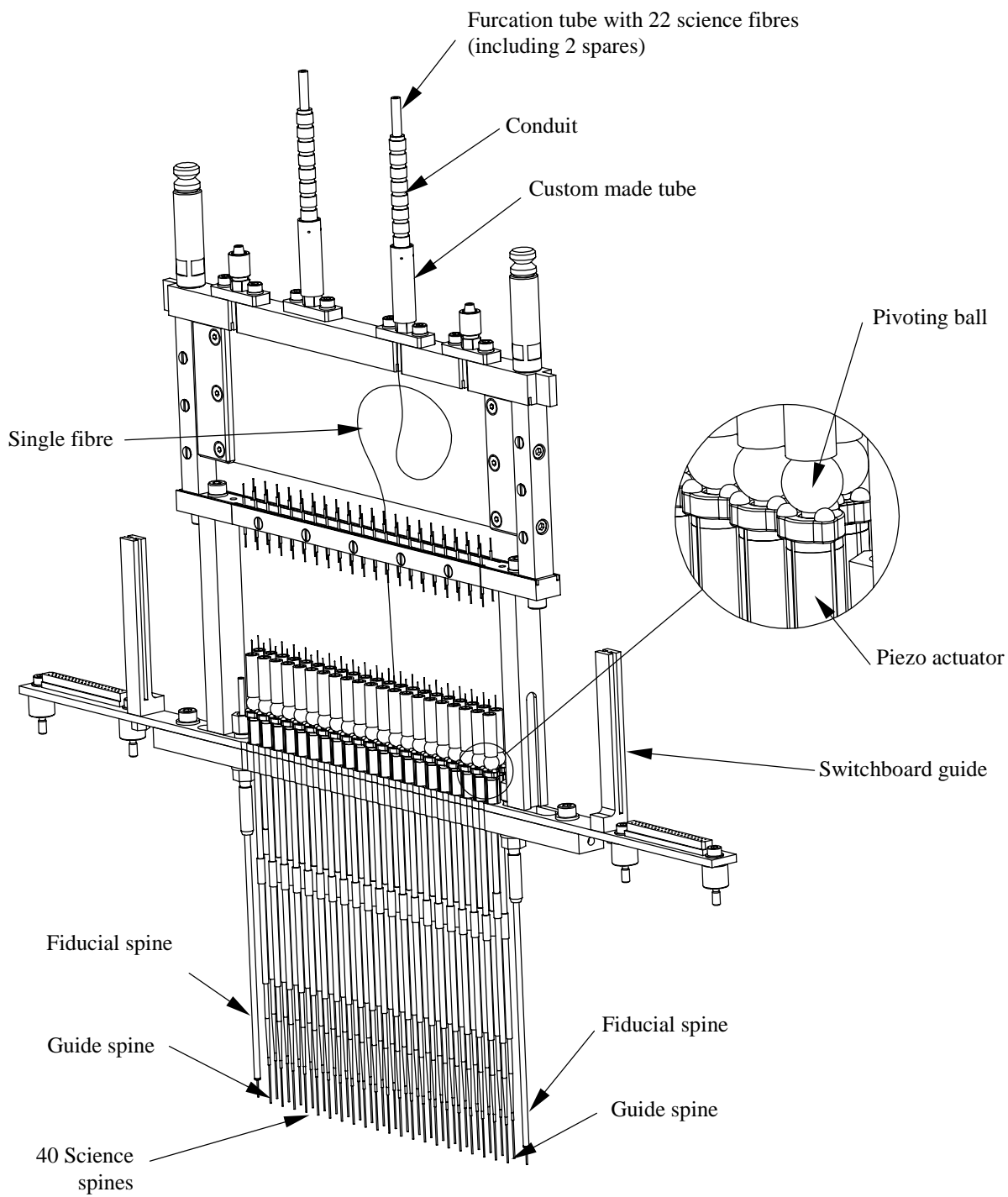

Figure 5. One of 12 identical Echidna positioner modules

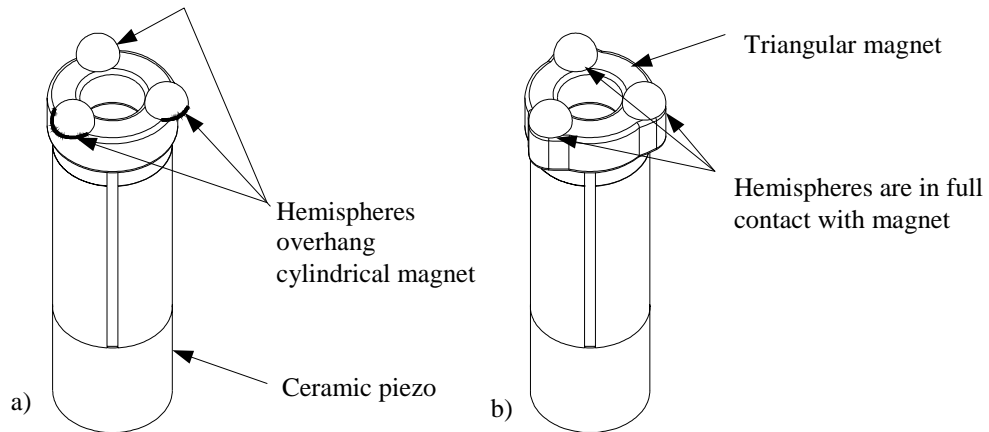

Figure 6. Two types of piezo actuators: a) with cylindrical magnet, b) with triangular magnet.

As the project required about 3000 hemispheres (including spare modules and prototypes) a method of mass manufacturing of the hemispheres while maintaining acceptable accuracy was needed.

Assembly of the module printed circuit board (PCB) was difficult. Magnetic repulsion and attraction between neighboring piezo actuators caused them to pop up and lean over, despite efforts to constrain them in the required positions.

Solutions

For adhesives the required properties are: good adhesion to metals and ceramics, high peel strength, high impact strength, good gap filling and rigid cure. After intensive testing, Loctite 326 was identified as best fitting our requirements. Some of the other adhesives considered were Loctite 290 and C2 cyanoacrylate, which failed thermal cycling tests.

The 2 mm hemispheres were coated with titanium nitride (TiN) significantly improving their wear resistance. Titanium nitride is much harder than 420 hardened chrome steel and also possesses a much lower wear rate. The pivoting ball of the spine remains a hardened chrome steel ball.

“Triangular” magnets were specially developed (Figure 6b). This magnet shape provides almost 100% contact area for each of the 3 hemispheres and the force imparted to the hemispheres by the pivot ball produces only shear stress in the cement layer.

The 2 mm diameter hemispheres were initially manufactured by grinding spheres after placing them onto flat ground steel plate and covering them with special wax. This resulted in very high (up to 90%) hemisphere loss, which usually occurred near the end of the grinding process when the holding force of the hemispheres was minimal. The wax was replaced by Durahold – an ultraviolet or visible light curable temporary adhesive - and leaving the hemispheres very slightly higher than true hemispheres (so the adhesive level remained slightly above the sphere’s center). The survival rate was then near 100%. The achieved tolerance on height (1.1 mm) for all hemispheres was ± 0.02 mm.

1.1.3. Science and Guide spines construction

Figure 7 shows details of the spine construction.

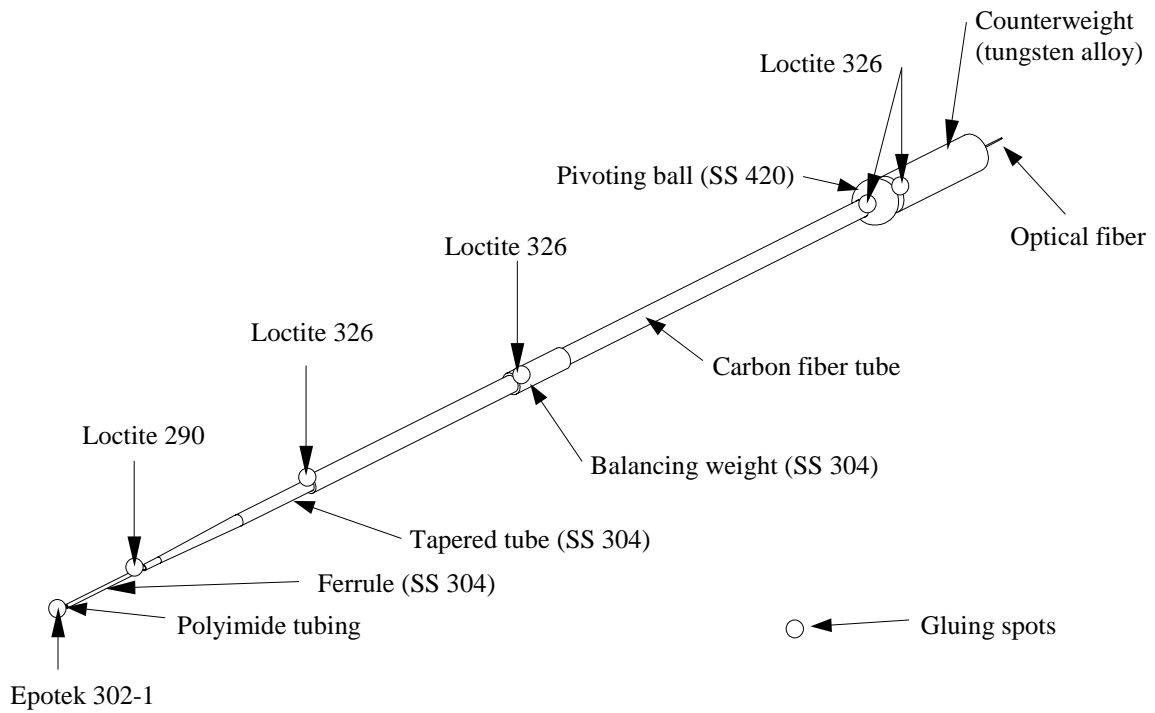

Figure 7. Science and guide spine construction.

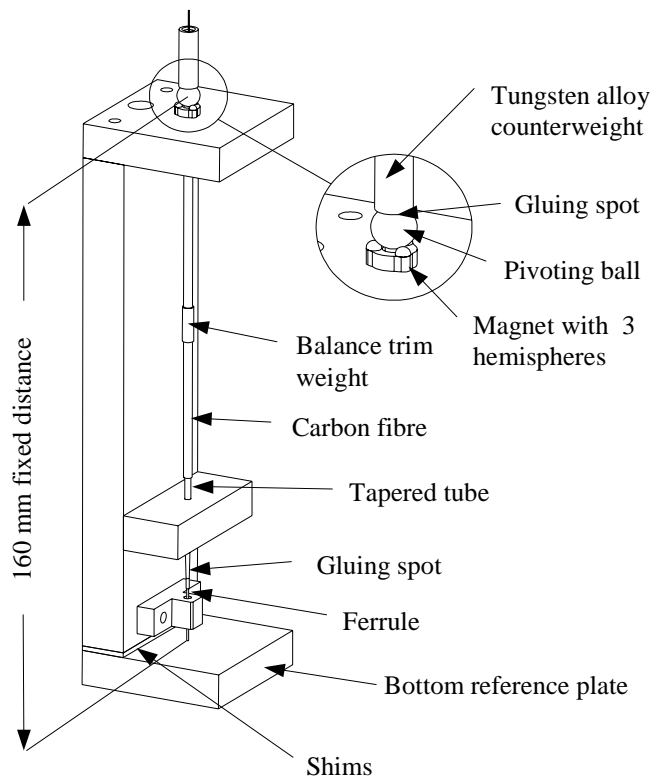

Figure 8. Science and guide spine assembly jig.

Challenges

So that length variation will not contribute excessively to the variation between spine tips in focus, every spine must be constructed to ensure its length from the tip to the centre of the pivot ball is $160 \text{ mm} \pm 15 \text{ }\mu\text{m}$ (see Figure 8).

All components of a spine must be coaxial so their ranges of travel will be closely concentric with their nominal centers. Every spine must be balanced about the center of the ball (the instrument is mounted at the prime focus of the Subaru telescope). Another requirement for the spines was that the differential deflection between any two spines during long observations must not be greater than $2 \text{ }\mu\text{m}$. Selection of appropriate adhesives to join the various materials was also important.

Solutions

For control of the spine accuracy, a special jig was designed and manufactured (see Figure 8). This jig sets the distance between the pivoting ball and the spine tip.

The jig is composed of a steel column screwed to top and bottom plates. A 3-point mount is located on the top plate. Glue is applied to the spine at the taper to carbon fiber joint (glue spot). With the glue still liquid, the spine is carefully threaded through the hole in the top plate. The ferrule at the fiber tip is located in precisely manufactured guiding holes in the jig to ensure accurate axial alignment of the spine assembly. The spine pivoting ball seats on the 3-point mount once in position. After the spine is inserted into the jig, the fiber tip is positioned to butt against the bottom plate and the taper to carbon fiber joint is left to cure. This process ensures spine length repeatability to the required accuracy. An additional sleeve, not shown on Figure 8, is attached to the top plate in order to set the alignment of the counterweight prior to gluing. The spines' length consistency was confirmed to $\pm 10 \text{ }\mu\text{m}$ for 90 % spines.

A number of adhesives were tested to ensure assembly integrity. Due to the fact that spine assembly involves joints between several materials including stainless steel, carbon fibre reinforced plastic, polyimide tube, tungsten alloy, and chrome steel, a few different adhesives were necessary (see Figure 7).

Differential deflection of any two spines was an issue as the carbon fiber tube diameter varied up to 10% and its section was somewhat elliptical. Careful selection was necessary to choose lengths that met our stringent requirements.

1.1.4. Spine tip positioning accuracy and module assembly

Challenges

The tolerance adopted for consistency of spine tip axial positions in the focal plane (i.e. locations in the Z direction), when the spine tips are at their central positions, is $\pm 50 \text{ }\mu\text{m}$. Including the effect of spine tilting, the limits that are tolerable for spine de-focus are $\pm 100 \text{ }\mu\text{m}$, which gives a blur circle diameter of up to 0.55 arc sec, while the fiber core diameter is to be equivalent to about 1.2 arc sec.

The de-focus error must be controlled by mechanical design, manufacturing processes and assembly procedures. The individual contributors (Figure 9 and Figure 10) to the Z error and the tolerances allocated them (not including spine tilting) are:

- Distance between mounting surface of the module to 3-point mounts: $\pm 15\mu\text{m}$.
- Distance from modules' mounting frame to instrument main structural plate: $\pm 20\mu\text{m}$

Every module should be capable of removal without disturbing the others, so considering the small clearances between neighboring modules, accurate positioning of the components in the X and Y directions is needed as well. Also, if the piezo actuator magnets were unequally distributed (such that neighboring mounts were closer together than intended), the magnetic interaction between neighbors could cause the spine drives to misbehave.

To maintain uniform spacing between all piezo actuators, the angular position of the triangular magnets is also important. Magnetic repulsion and attraction greatly complicate the assembly of modules. Selection of appropriate adhesives to join various types of materials was also a consideration.

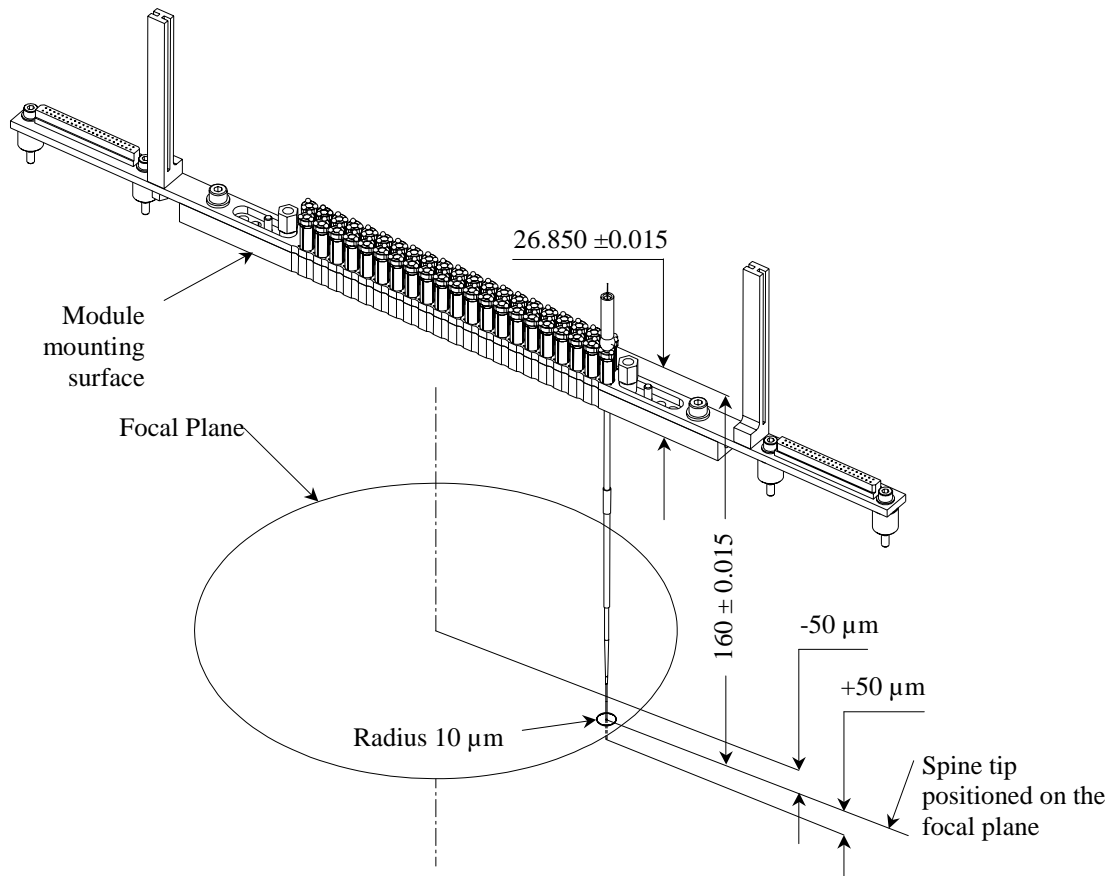

Figure 9. Spine tip positioning accuracy.

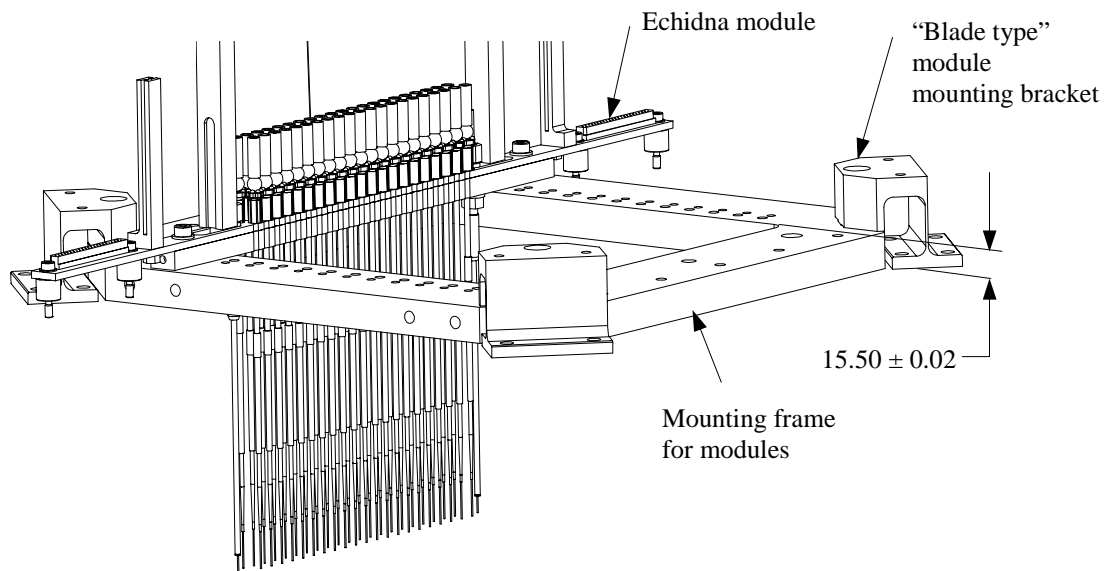

Figure 10. Module base positioning accuracy.

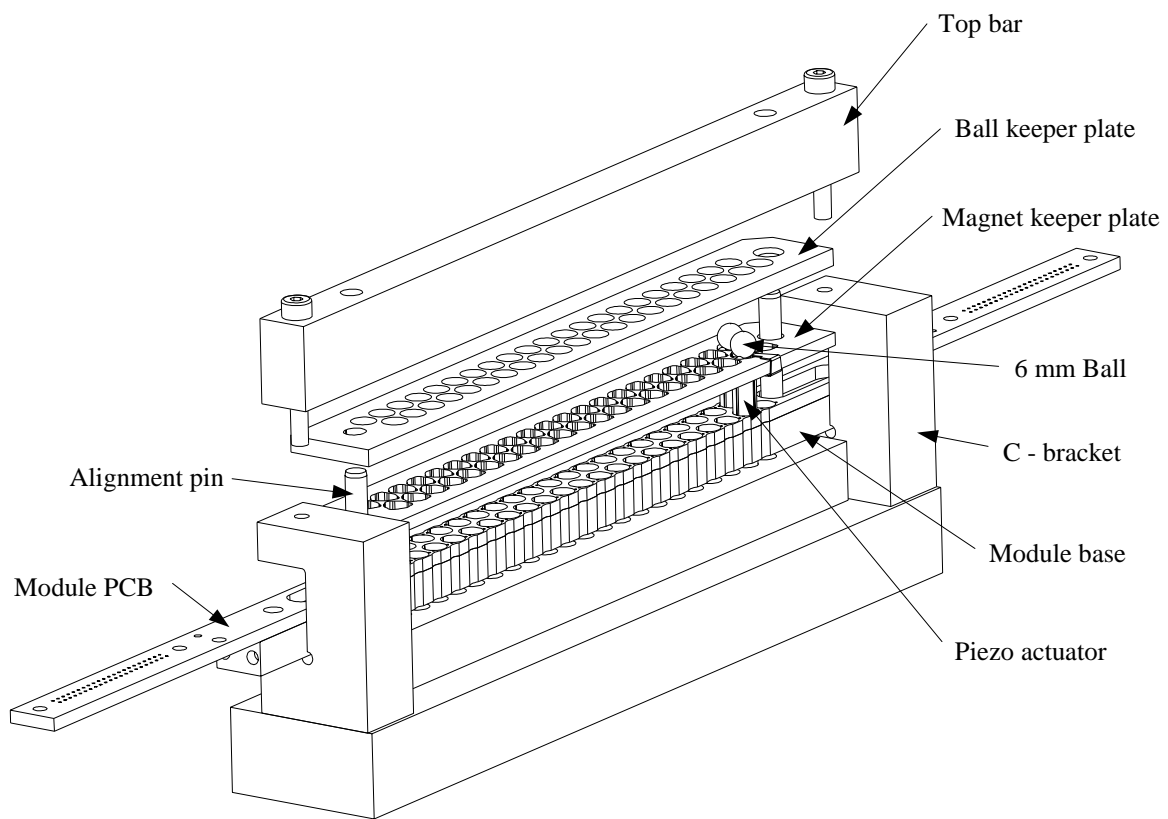

Figure 11. Module assembly jig.

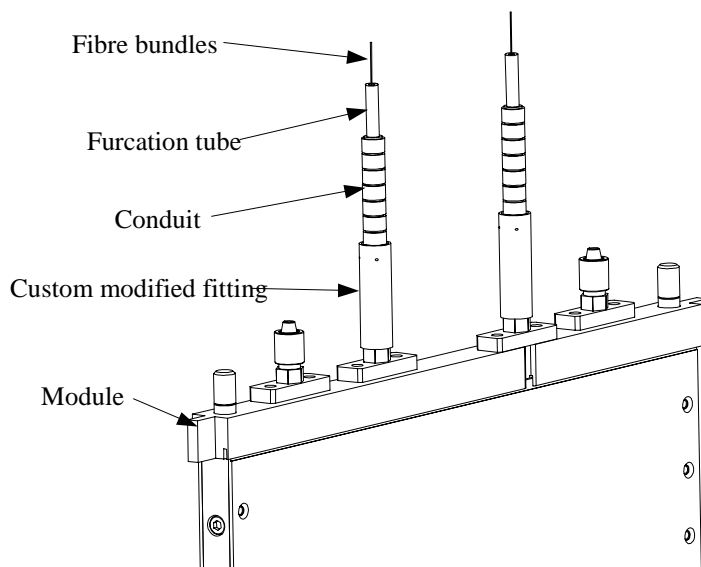

Figure 12. Protection of optical fibres.

Solutions

To address the modules' dimensional requirements, a jig (Figure 11) was designed. The objective of the jig is to ensure that the distance between the pivoting ball centre (3-point mount centre) and the bottom (mounting) surface of the module is maintained within several microns. This is accomplished by using two identical c-brackets and a flat top bar. The c-brackets are used to mount the module on the lower face while the top is for the bar. The bottom surface of the bar is extremely flat. This creates a reference plane for the 6 mm grade 5 balls which represent the spine pivot balls.

To ensure that a full contact occurs between the balls and the top bar, miniature springs (not shown on the drawing), placed inside the piezos, act on the magnets, pushing them and the ball resting on the hemispheres, against the top bar.

One of the challenging tasks in the jig design was to ensure precise positioning of the pivoting balls in the XY plane and to constrain the triangular magnets angularly. The best solution for both problems was a magnet keeper plate made of stainless steel flat bar with precise laser cut triangular profiles. These holes are slightly larger than the triangular magnet to allow for errors with overhanging hemispheres and slight variations in magnet geometry. This is important during removal of the keeper plate as even a little force exerted upon a piezo can damage it. Another plate is placed above the keeper plate to ensure accurate positioning of the 3-point mounts. It has precisely drilled holes to accept balls (exactly the same size as the pivoting balls of the spines). Together the two plates give precise location in the XY plane and adequate angular positioning of the piezo actuator.

1.1.5. Module frame mountings

Challenges

The module support plate carrying all the modules must retain an accurate position relative to the telescope axis at all zenith angles. The plate is made of Stavax steel (Uddeholm tool steel grade) to match the material of the 12 module bases while the main structural plate on which Echidna is mounted is made of MIC-6 aluminum alloy. These materials have significantly different coefficients of thermal expansion and therefore cannot be rigidly connected.

Solutions

To cope with the differential expansion, flexible mounting brackets of a "blade" type were designed (Figure 10). In the radial direction they can flex with little stress, allowing thermal expansion/contraction of the two materials. In the perpendicular direction they are rigid enough to deflect only a fraction of a micron under the complete Echidna assembly load. This approach makes for easy and safe handling of fibres in the case of the removal of a module.

1.1.6. Protection of optical fibers

The complete module is a very complicated and expensive unit so its protection from accidental damage was always a very high priority. The 40 optical fibers on their way to the fiber connector are especially vulnerable. For protection, two bundles, each of 20 fibers, were placed in two furcation tubes (see Figure 12).

The furcation tubes are then fixed into custom modified fittings, which also hold bushes retaining corrugated conduit. This approach makes the fibers perfectly safe and easily handled in the case of the removal of a module.

1.2. Focal plane imager mechanical engineering

1.2.1. FPI functions

The FPI is a dual purpose XY stage located between the corrector and the Echidna fiber positioner, carrying optics to image both the sky and backlit fibers. The FPI functions include calibration of the Echidna system on the telescope and accurate measurement of the position of the Echidna spine tips.

1.2.2. FPI details

Two un-cooled cameras are fitted. A Pulnix CCD camera (TM-62EX), referred to as the "spine camera", images a subset of the backlit fibers via a telecentric lens. A high sensitivity Watec CCD camera (WAT-902H CCIR) images a

section of the sky via a 45° mirror and is referred to as the “sky camera”. The FPI can “look” up (via the spine camera) and down (via the sky camera) along the same axis, so it can directly compare star and spine tip positions.

During re-configuration, spine tips, illuminated by back-lighting through the fibers, are imaged by the spine camera to provide the positional feedback to the control software. After a few iterations, the fibers are positioned to the required accuracy. The FPI calibration is up-dated during each Echidna re-configuration by recording the images of the tips of several fiducial spines (one at each end of each module).

1.2.3. Calibration of FPI

To calibrate any non-linearities in the optical scales as well as departures from straight orthogonal motions in X and Y, the spine camera reads the positions of a grid of holes on a glass plate which is mounted in place of the Echidna assembly. The FPI calibration plate is shown in Figure 13. It has a precisely deposited pattern of 100µm diameter holes in a metal coating (with positional accuracy of about 1µm).

The hole pattern contains two grids. The large grid, on 20 mm pitch, is used for calibrating the FPI carriage positioning. In the middle of the plate is a grid with pitch 2 mm for calibrating the distortion of the spine camera lens. This camera measures the position of each hole (backlit by an electro luminescent sheet). Temperatures are measured during the calibration and calculations allow for the difference in thermal expansion between the glass and the FPI encoder scales.

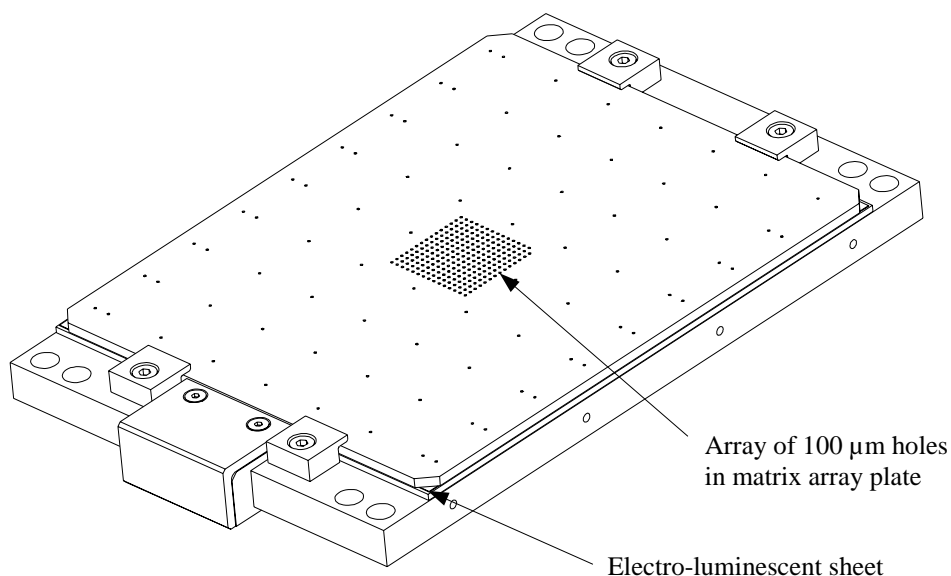

Figure 13. Calibration matrix for FPI.

1.2.4. FPI drive and encoding

The FPI has 2 carriages referred to as the X and Y carriages (Figure 3). The X-axis carriage is the larger as it carries the Y-axis drive, Y-axis linear encoder, and Y-axis carriage. Both carriages are mounted to the FPI support plate.

The X and Y drives use brushless servomotors with incorporated resolvers. Each drive is through a bellows coupling, a lead screw, and a recirculating ball nut linked to the carriage. These motors have high power to size ratio, giving good acceleration capabilities. Both motors are equipped with holding brakes, which are applied only when the drive is stationary. The resolver provides position and velocity information to the servo motion controller for positioning and motor commutation. There are optical linear encoders on both X and Y motions but it was found preferable to use only the resolvers for positional feedback in the servo loops because, if the encoders were used, the compliance in the drive between the motor and the carriage motion led to slow settling of the motion. The resolvers, which are directly coupled

to the motor rotors and have resolution equivalent to about 0.1 μm , allow very fast servo control. It is not necessary that the FPI carriages be precisely positioned when the spine images are taken, only that the precise positions are known (from readings of the optical encoders) at the times of the exposures.

1.3. Electronic engineering

1.3.1. Electronics design challenges

The major challenge for electronics was the design of the control system for the piezoelectric actuators that move the guide and science spines. To drive each of these actuators independently through the X and Y axes in real time would require 4 connections per actuator, 1008 high voltage signals (up to 150V is used) and over 2000 connections. Fortunately, fully simultaneous driving of all actuators was not essential, so a compromise between reconfiguration time, cost, and practical implementation was possible. The decision was to reduce the number of high voltage sources to a single source per axis direction and to switch these sources to the actuators in pseudo real time.

The number of wires required to control the actuators remained the same and also needed to be optimized. The piezoelectric actuators have 4 equally spaced electrodes on the outer surface. By electrically connecting two neighboring electrodes the number of wires required to drive an actuator could be reduced by 25% while maintaining positioning speed and functionality. This also allowed multiple actuators to be joined along the connected electrodes, further reducing the number of wires.

The next problem was how to connect the high voltage signals to each piezoelectric actuator while providing a maintainable system. Access to connect wires to the electrodes and for any maintenance would have been very difficult with all piezoelectric actuators on single plate, so it was decided to divide the array of piezoelectric actuators into 12 modules, each with 2 rows of 21 actuators. Then the electronics needed to provide 85 connections for each module and a design decision was made to use a long rectangular printed circuit board for the electrical connections to the piezoelectric actuators. Problems still remained for the number of wires required for actuator control and where the switching should be located. This problem was solved by having the module printed circuit board directly connect to two motherboards, Echidna A and Echidna B, mounted either end of the module. These motherboards also allowed the switching to be located with the modules, greatly reducing the number of control wires to the array of modules. The function of switching is grouped on printed circuit board responsible for switching to the individual actuators in each module group.

There are 24 switch boards necessary to drive the 504 piezo actuators and switching is achieved using MOS switches to route the common high voltage waveform. Each switch can allow + high voltage, - high voltage or high voltage return to either X or Y electrodes of the controlled actuator. This was a design compromise to reduce the number of switches required for high voltage routing. The result is that actuator positioning speed was reduced by 50% as the X and Y axis could no longer be positioned simultaneously.

The mechanical constraints required each of these printed circuit boards to be limited in width to 12.33mm. This presented a challenge in providing sufficient track to track spacing for the high voltage (300V maximum) on the printed circuit board. It was not practical to pass all the tracks to a single connector at one end of a multilayer printed circuit board, so a Datamate 44 pin connector was chosen for each end of the board to provide for 85 connections and the piezoelectric actuators were wired so a group of 21 were connected to each end connector. The final wire requirement for each group was 43 wires. A printed circuit board, called the module printed circuit board, was made with 24 layers; it is 420 x 12.33 x 3.1mm and provides a basis for the control electronics. The populated module printed circuit board and the metal base plate together form the basic FMOS/Echidna module. The final challenge was controlling the complete array of piezo actuators. The switching control is achieved by using a high speed serial link that interfaces to the Echidna A motherboard via an interface board. The serial data is then de-multiplexed into each switch board, which retains the switching state in D-type flip flops.

1.3.2. Spine Operation Electronics Overview

Movement of spines is achieved by applying a high voltage saw tooth waveform across the piezoelectric electrodes. Large movements can be achieved by repeating saw tooth cycles to the actuator. The step size is determined by the peak voltage of the saw tooth waveform. For coarse positioning, the peak voltage applied to the piezoelectric actuators is 150V and for fine positioning it is 80V.

Pseudo real time movement of the spines is achieved by applying the high voltage waveform to multiple actuators on a single axis simultaneously. The number of saw tooth cycles in X and Y to move a spine from its present to the desired position is calculated, based on the FPI measurement and a calibration of the step size for that particular spine. The saw tooth signal is sent to the switches for all actuators and each switch opens after the appropriate number of cycles has been applied. This is performed in the X then the Y direction. This is repeated until the spine tip positions are within the 10 μ m position tolerance.

1.4. Interfaces and environment

An important constraint on the mechanical design was the need to fit within the new Prime Focus Unit (PFU) which was being designed in Japan and was to depart as little as possible from the existing prime focus unit used on Subaru. In particular, there was no spare room around the FPI – some openings had to be made in the cylindrical housing to allow for the full range of FPI motion. It was necessary to share the space between the corrector lens and the focal plane with a Shack-Hartmann camera, which is used for calibrating the telescope's primary mirror active control system. There will be electrical interlocking to prevent collisions, by allowing either the FPI or the Shack-Hartmann optical units to be driven from its park position only when the other is parked.

The Subaru telescope is at an altitude of 4200 m with a typical atmospheric pressure of 614 mb. The temperature ranges from -10°C to +10°C and humidity from 15% to 80%. So careful attention had to be paid to the observatory conditions in designing Echidna and the FPI, especially allowing for the low minimum temperature. To check that the system would perform satisfactorily, tests were made with a prototype Echidna module and a prototype FPI (having only X motion) in an environmental chamber down to -10° C. There were problems with operating the chamber on a warm humid Sydney day – the relative humidity was 100% or very near it whenever the temperature was below about -5°C. So Echidna was given unintended tests of survival from frost forming on the actuators. There was some misbehavior of the spine drives while frost was present – not surprising with up to 150 V applied to the electrodes – but the system recovered full performance as soon as it was dry.



Figure 14. Module on measuring jig.



Figure 15. Echidna modules.

ACKNOWLEDGMENTS

All the members of the FMOS/Echidna team at the AAO have contributed to the development of the project.

REFERENCES

1. Anna Moore, Peter Gillingham, Jason Griesbach, Masayuki Akiyama, "Spine Development for the Echidna Fiber Positioner," in *Optical and IR instrumentation and detectors*, M. Iye, A. Moorwood, ed., *Proc. SPIE* **4841**, pp. 1429-1439, 2003.
2. P. Gillingham et al, "The Fiber Multi-Object Spectrograph (FMOS) Project: the Anglo-Australian Observatory role," in *Optical and IR instrumentation and detectors*, M. Iye, A. Moorwood, ed., *Proc. SPIE* **4841**, pp. 985-996, 2003.
3. P. Gillingham, S. Miziarski, M. Akiyama, V. Klocke, "Echidna-A Multi-Fiber Positioner for the Subaru Telescope," in *Optical and IR instrumentation and detectors*, M. Iye, A. Moorwood, ed., *Proc. SPIE* **4008**, pp. 1395-1403, 2000.